

Reclosers

Electrical Apparatus
280-10

Types E, 4E, V4E, H, 4H, V4H, **L**, V4L, **(Single-Phase)**; 6H, V6H (Three-Phase) Recloser

DESCRIPTION

Kyle® Types E, 4E, V4E, H, 4H, V4H, L, and V4L single-phase reclosers (Figure 1) and Types 6H and V6H three-phase reclosers (Figure 2) provide reliable, self-contained distribution-circuit overcurrent protection at low initial cost, and require minimal service. Because most line faults are temporary in nature, they will clear after only momentary circuit interruption; therefore, permanent outages usu-



Figure 1. **Type L is a typical single-phase hydraulically-controlled oil circuit breaker.** 83417KM-A



Figure 2. **Type 6H recloser provides single-phase tripping and three-phase lockout.**

ally are prevented. Automatic circuit reclosers both improve customer service and reduce operating costs.

A summary of all available reclosers—ratings, basic characteristics, and applications—is included in Catalog 280-05.

BASIC RATINGS AND CHARACTERISTIC FEATURES

Reclosers in the E, H, and L groups include most of the single-phase reclosers produced by Kyle

Switchgear. The three-phase reclosers—Types 6H and V6H—are included in Catalog 280-10 because they adapt three single-phase interrupting structures with a common lockout mechanism. In operation, these reclosers sense line current in each phase individually and trip individually; however, if one phase sequences to lockout, all phases lock out.

Reclosers can be installed on poles or in substations to protect lines requiring the ratings shown in Table 1.

TABLE 1
Basic Ratings

Type	Nominal Voltage (kV)	Max Continuous Current (amps)	Max Interrupting Current (symmetrical amps)			
			@2.4—4.8 kV	@4.8—8.32 kV	@ 8.32—14.4 kV	@24.9 kV
Single-Phase						
H	2.4—14.4	50	1250	1250	1250	—
4H	2.4—14.4	100	3000	2500	2000	—
V4H	2.4—14.4	200	3000	2500	2000	—
L	2.4—14.4	280	6000	5000	4000	—
V4L	2.4—14.4	280	6000	6000	6000	—
E	24.9	100	—	—	—	2500
4E	24.9	280	—	—	—	4000
V4E	24.9	280	—	—	—	6000
Three-Phase						
6H	2.4—14.4	100	3000	2500	2000	—
V6H	2.4—14.4	200	3000	2500	2000	—

Both single-phase and three-phase reclosers are hydraulically controlled. Tripping is initiated by a series-connected coil. Current-carrying and interrupting capacities vary with the operating coil's rating, which is selected to meet circuit requirements. A choice of dual time-current characteristics permits coordination with other protective devices. A non-reclosing feature (Figure 3), standard on all Kyle reclosers, is set with a hookstick-operated lever for one operation to lockout without removing the recloser from service.

Two types of interrupters are available:

1. In Types E, 4E, 4H, L, and 6H reclosers, current interruption takes place in oil.
2. Types V4H, V4L, V4E, and V6H reclosers are equipped with vacuum interrupters. A major advantage of vacuum interrupters is reduced maintenance frequency.

APPLICATION

Both single- and three-phase H-group and L-group reclosers are designed, tested, and rated for operation on 14.4-kV three-phase systems where the line-to-ground voltage is 8.32 kV. Bushing insulation strength and other line-to-ground insulation is designed for this 8.32-kV stress.

The standard recloser (110 kV BIL) is not suitable for operation on single-phase taps of 14.4/24.9-kV systems. Operation on these higher voltage systems will stress the insulation at the 14.4-kV level, resulting in excessive radio influence voltage and deterioration of the insulation.

Types E, 4E, and V4E reclosers can be used for operation on single-phase taps of a 20/34.5-kV system where the 150-kV BIL rating is satisfactory. The bushings and other line-to-ground insulation are adequate for the 20 kV line-to-ground voltage stress. Since the interrupting capability is 24.9 kV, application on this system is limited to single-phase taps only. Operation on the three-phase line can result in a single recloser attempting to interrupt the full 34.5-kV voltage, which is in excess of its rating.

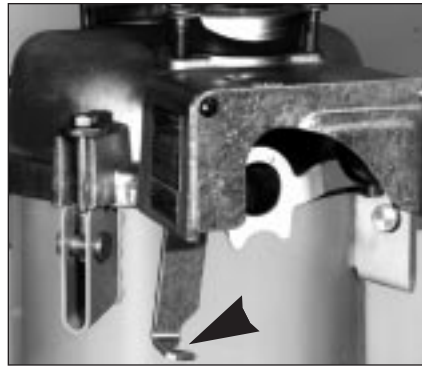

Figure 3. The non-reclosing feature is set with a handle under the sleet hood (see arrow). When the handle is down (left), the recloser will trip on overcurrent and lock out without reclosing. When the handle is up (right), the recloser will operate according to its internally set program.

SURGE PROTECTION

Reclosers operate best when protected with surge arresters. On line applications, arrester protection is recommended on both sides of the recloser. If protection is to be provided on one side only, install the arrester on the source side. In substations, arresters are located on the load side. Cooper Power Systems distribution-class arresters provide excellent protection; see Catalog 235.

ORDERING INFORMATION

To order an E-, H-, or L-group recloser:

1. Use the chart below to construct a catalog number that describes the required recloser.
2. From Tables 2 through 13, specify the catalog number that describe the required recloser accessories and mounting equipment.

Constructing a Catalog Number

To order a basic Type 4H recloser with a 100-amp coil, time-current Curve B, and two fast and two retarded operations to lockout, the catalog number would be constructed like this:

KH Basic letters for H-group reclosers:
 E-group reclosers: KE
 L-group reclosers: **KL**

4 Recloser type:
Omit for Types E or L:

- 1 for Type H;
- 4 for Type 4H or 4E;
- V4 for Type V4H, V4E, or V4L;
- 6 for Type 6H;
- V6 for Type V6H.

100 Continuous current rating of series-trip coil:
 Type E : 5, 10, 15, 25, 35, 50, 70, or 100 amps;
 Type 4E: 50, 70, 100, 140, 200, or 280 amps;
 Type V4E : 15, 25, 35, 50, 70, 100, 140, 200, or 280 amps;
 Type H : 5, 10, 15, 25, 35, or 50 amps;
 Type 4H : 5, 10, 15, 25, 35, 50, 70, 100, 140, or 200 amps;
 Type 6H : 5, 10, 15, 25, 35, 50, 70, or 100 amps;
 Type V6H: 5, 10, 15, 25, 35, 50, 70, 100, 140, or 200 amps;
Type L: 25, **35**, 50, 70, 100, 140, 200, or 280 amps;

B Delayed time-current curve:
 Types H, 4H, V4H, 6H, or V6H: B or C;
Types E, 4E, V4E, or L: B, C, or D.
 If all fast operations are required, insert letter A.

2 Number of fast A-curve operations:
 0, 1, **2**, 3, or 4.

2 Number of delayed operations:
 0, 1, **2**, 3, or 4.

} Fast + delayed operations not to exceed 4.

KH 4 100 B 2 2

KH4100B22 is the catalog number for the required Basic Type 4H recloser.

ACCESSORIES
Types E, 4E, V4E, L, and V4L (Single-Phase) Reclosers

TABLE 2
Shunt Lockout and Lockout Indication; Factory Installed

Description	Type E	Type 4E	Type V4E	Type L	Type V4L
Shunt-lockout mechanism*	KA193E	—	KA193E	—	KA193E
Lockout-indicating switch..	KA194E**	KA86L2	KA86L2	KA86L1	KA86L2

*Specify operating voltage: 120 or 240 Vac
 **Includes shunt-lockout mechanism.

TABLE 3
Bushings; Factory-Installed

Description	Type E	Type 4E	Type V4E	Type L	Type V4L
17-in.-creepage bushings..	—	—	—	KA126L	KA121V4L
26½-in.-creepage bushings	KA188E	KA149E4-1	KA149E4-1	—	—

TABLE 4
Hardware; Factory-Installed

Description	Type E	Type 4E	Type V4E	Type L	Type V4L
Two-bolt flat pad connectors; set of two	—	—	—	KA146L1	—

TABLE 5
Bushing Current Transformer for Field Installation

Description	Type E	Type 4E	Type V4E	Type L	Type V4L
Slip-on bushing current transformer kit; one BCT per kit..	KA712L1	KA712L1	KA712L1	KA712L1	KA712L1

TABLE 6
Mounting Equipment

Description	Type E	Type 4E	Type V4E	Type L	Type V4L
Crossarm mounting hanger; two required for each recloser	KA39H	KA39H	KA39H	KA39H	KA39H

ACCESSORIES

E-, H-, and L-group reclosers can be supplemented with factory- or field-installed accessories. Select the accessories and mounting equipment required from Tables 2 through 13. Detailed information on mounting equipment is in Catalog 280-85.

1. Shunt lockout mechanism (Types E, 6H, and V6H only) enables remote electrical trip and lockout.
2. Lockout-indicating switch (all types) provides remote indication of recloser lockout.
3. Bushings with 17-in. creepage distance (all H-group and L-group) increase creepage distance from standard bushing distances of 103/8 in. for H; 107/8 in. for 4H, V4H, 6H, V6H; 113/4 in. for L and V4L.
4. Bushings with 261/2-in. creepage distances (Types E, 4E, and V4E increase creepage distance from standard bushing distances of 135/8 in. for E and 17 in. for 4E and V4E.
5. Slip-on, multi-ratio bushing-current transformer kit for field installation (all types) is easily installed at low cost and is convenient for metering. Taps are available for 100, 150, 200, 250, 300, and 450:5 amp ratio; 5% accuracy.

ACCESSORIES**Types H, 4H, and V4H (Single-Phase) Reclosers****TABLE 7**
Lockout Indication; Factory-Installed

Description	Type H	Type 4H	Type V4H
Lockout-indicating switch ..	KA161H	KA161H	KA161H

TABLE 8
Bushings; Factory-Installed

Description	Type H	Type 4H	Type V4H
17-in.-creepage bushing ...	KA193H	KA60H4	KA51V4H

TABLE 9
Mounting Equipment

Description	Type H	Type 4H	Type V4H
Crossarm mounting hanger	KA39H*	KA39H**	KA39H**

*One required.

**Two required.

Type 6H, V6H (Three-Phase) Reclosers**TABLE 10**
Lockout and Lockout Indication; Factory-Installed

Description	Type 6H	Type V6H
Lockout-indicating switch.....	KA96H3-2	KA96H3-2
Shunt-lockout mechanism*	KA1HS6	KA1HS6
Ground-fault lockout**	KA123H3-2	KA123H3-2

*Specify operating voltage 120 or 240 Vac; 12, 18, 20, 24, 36, 48, or 125 Vdc.

**Specify minimum-trip current (5, 10, 20, 35, 50, 70, 100, 140, or 200 amps) and time delay (3, 5, 7, 9, or 11 seconds)

TABLE 11
Bushings; Factory-Installed

Description	Type 6H	Type V6H
17-in.-creepage bushings	KA31H6	KA51V6H

TABLE 12
Bushing Current Transformer for Field Installation

Description	Type 6H	Type V6H
Slip-on bushing current transformer kit; one BCT per kit.....	KA712L1	KA712L1

TABLE 13
Mounting Equipment

Description	Type 6H	Type V6H
Double crossarm bracket or substation hanger	KA19H3	KA19H3
Substation mounting frame.....	KA46H6	KA46H6
In-line broadside pole-mounting hanger	KA116H3	KA116H3
Surge arrester mounting bracket.....	KA126H3	KA126H3
Tank-lifting windlass for substation mounting frame	KA584R2	KA584R2

FEATURES AND DETAILED DESCRIPTION

Construction Features

BASIC FEATURES

E-, H-, and L-group reclosers are designed for long service life with minimum maintenance. Figure 4 describes the parts of the single-phase reclosers.

Heads are aluminum castings. Heavy-gage steel tanks are finished with an inhibiting epoxy prime coat and finish-coated with thermosetting acrylic paint. Finish color is light gray. Munsell 5BG 7.0/0.4.

A Buna-N o-ring gasket assures an oiltight seal between head and

tank. The gasket is confined in a groove, providing controlled compression.

Insulating supports connect the hydraulic mechanism to the head. Made of filament-wound glass epoxy, these supports provide high mechanical and dielectric strength and moisture resistance.

With the exception of Types V4E, V4H, V4L, and V6H, all reclosers described in Catalog 280-10 have oil interrupters; Types V4E, V4H, V4L, and V6H are equipped with vacuum interrupters. Kits are available for field conversion of 4H and 6H reclosers from oil to vacuum interruption. Type L reclosers can-

not be converted from oil to vacuum interruption.

Mechanisms have been thoroughly field-proven through many years of service. They are designed and built in accordance with ANSI Standard C37.60.

For more detailed information on construction of H-group reclosers, ask for Reference Data R280-10-1; for E-group and Type L reclosers, specify R280-10-2.

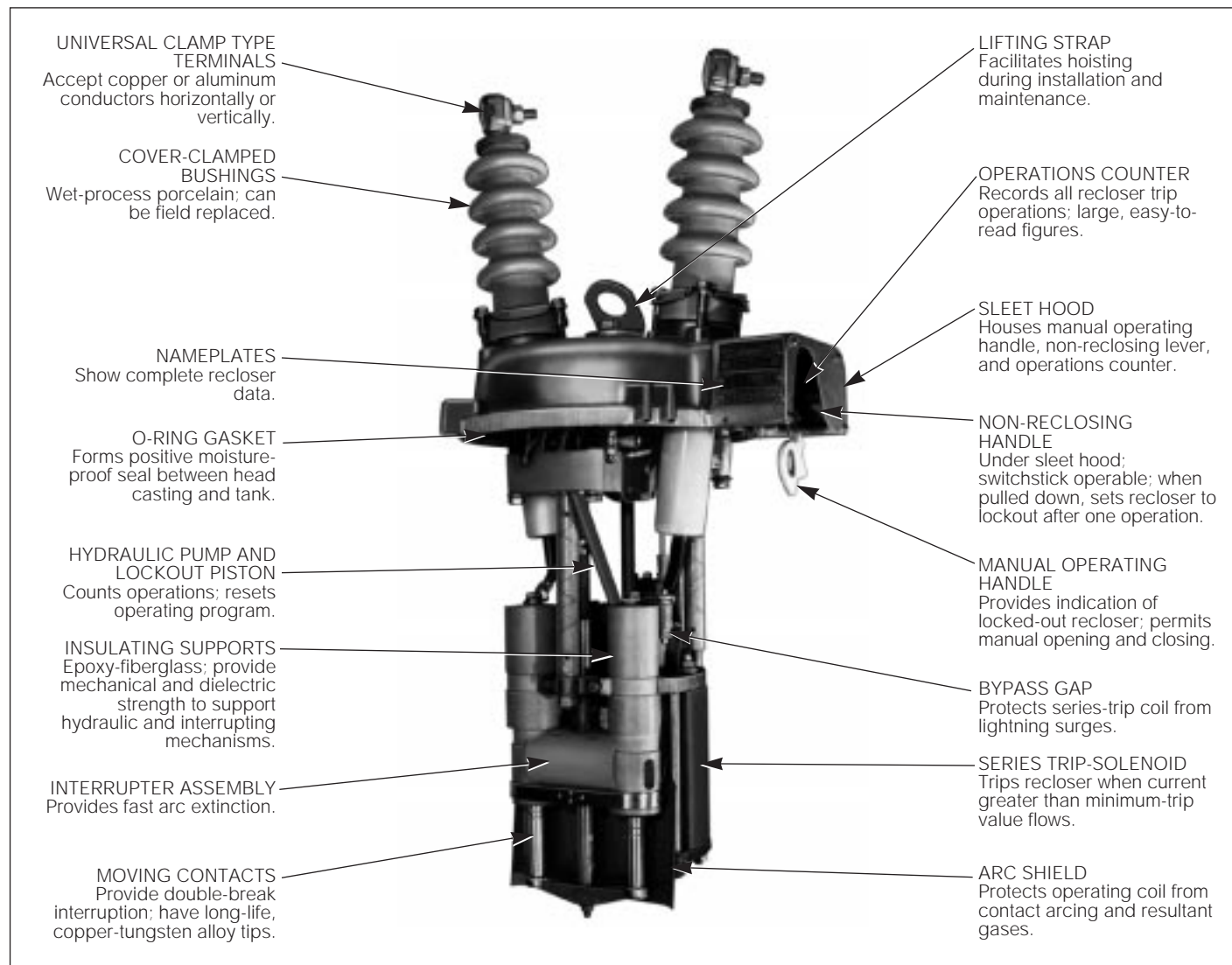

Figure 4.
Untanked view of typical single-phase recloser (Type L shown).

Interrupter and Contact Construction

Oil Interrupter

Contacts—silverplated copper-tungsten alloy to resist arc erosion—are arranged to give two breaks in series. Different interrupter and contact configurations are employed in the various recloser types but all oil interrupters are designed to provide fast arc extinction and self-cleaning of the contacts through a wiping action. Type H reclosers feature a wiping contact design; Types 4H, 6H, E, 4E, and L employ a bayonet contact design.

Vacuum Interrupter

Arc interruption in Types V4H, V4L, V4E, and V6H reclosers is fast—arcing time is generally less than 1/2 cycle. Arc energy is low, minimizing mechanical stress. Also, contact erosion is substantially reduced, contributing to long service life without contact maintenance.

Unaffected by ambient temperature, contaminants, humidity, or altitude, vacuum interruption provides maximum reliability. Because there are no arcing byproducts to contaminate the insulating oil, inspections are fewer and maintenance costs are lower.

The vacuum interrupter is fully interchangeable with the oil interrupter used in Type 4H and 6H reclosers. A replacement assembly is available for quick field installation.



Figure 5. Untanked view of typical three-phase recloser (Type 6H shown).

BASIC OPERATION

Kyle E-, H-, and L-group reclosers are series-trip-solenoid-operated and hydraulically controlled. Series tripping provides simple and reliable operation since the tripping energy is taken directly from the fault itself. During tripping, the mechanism stores energy for reclosing. Hydraulic control permits accurate coordination with other protective equipment.

The two three-phase reclosers in the H group—Types 6H and V6H—consist of three single-phase reclosers in one tank (Figure 5), mechanically interlocked for lockout operation. This permits initial independent operation of a single phase in the event of a fault on any one phase. Should the fault persist after the initial operation and the phase proceed to lockout, the mechanical interconnection opens and locks out the other two phases as well. A separate counter on each phase accumulates information for operating records.

For more detailed information on operation of H-group reclosers, ask for Reference Data R280-10-1; for E-group and L-group reclosers, specify R280-10-2.

Non-Reclosing Operation

All E-, H-, and L-group reclosers are equipped with a non-reclosing feature. Simply by moving an externally operable handle with a hook-stick, the recloser can be set for one operation to lockout. The non-reclosing feature is a valuable tool when hot-line work is necessary. Should an overcurrent occur while the non-reclosing feature is activated, the recloser will trip according to the first time/current curve programmed in its operating sequence and then lock out. When the feature is deactivated, the recloser will operate normally according to the internally programmed sequence.

Series-Trip Solenoid

Fault-current sensing is provided by a series-connected solenoid coil that carries line current. When a fault occurs, tripping is initiated by the solenoid plunger.

The plunger, normally held at rest by the closing springs, is drawn into the coil by the magnetic force generated by the fault current. Downward travel of the plunger overtoggles springs in the contact assembly that open the recloser contacts. The same motion charges the closing springs in preparation for a reclosing operation.

When the circuit is opened, the solenoid coil is deenergized, allowing the closing springs to close the contacts and simultaneously return the plunger to its original position.

Contact operating speeds—controlled entirely by the springs—are independent of the magnitude of the fault current. Total time to contact opening is proportional to the level of fault current passing through the series-trip solenoid.

When the recloser operates to lockout, the hydraulic mechanism releases a lock-out spring and mechanism, preventing the plunger from returning and the contacts from reclosing.

The series-trip coil is capable of withstanding forces caused by maximum-rated fault currents and is effectively shunted with a bypass gap for surge protection.

Hydraulic Control Mechanism

The hydraulic control mechanism provides selectivity in timing enabling flexibility in application and coordination with other equipment. All timing is governed by the hydraulic mechanism which

1. controls the timing before contact opening;
2. establishes the time delay before the contacts reclose;
3. counts the number of operations;
4. causes the recloser to lock out when the preset number of trip operations has been completed.

Variations of timing characteristics and sequences can be programmed for a maximum of four operations. When a recloser is programmed for both fast and retarded operations, the fast operations—involving no intentional time delay—occur first in the sequence according to the recloser's A curve time-current characteristic. Retarded operations are according to the recloser's B or C time-current curve (B, C, or D curve for Types E, 4E, and L). See Time Current Curves R280-91-10 for Type E reclosers; R280-91-8 for Type 4E; R280-91-1 for Type H; R280-91-2 for Types 4H, V4H, 6H, and V6H; R280-91-3 for Type L; and R280-91-15 for Types V4L and V4E.

RATINGS**TABLE 14****Single- and Three-Phase Recloser Ratings**

Trip-Coil Continuous Current (amps)	Minimum Trip Current (amps)	Interrupting Current (rms symmetrical amps)		
Type H Single-Phase; 50 Amps Maximum				
@ 2.4 through 14.4 kV				
5	10	125		
10	20	250		
15	30	375		
25	50	625		
35	70	875		
50	100	1250		
Types 4H Single-Phase and 6H Three-Phase; 100 Amps Maximum				
		@ 4.8 kV	@ 8.32 kV	@ 14.4 kV
5	10	200	200	200
10	20	400	400	400
15	30	600	600	600
25	50	1000	1000	1000
35	70	1400	1400	1400
50	100	2000	2000	2000
70	140	2800	2500	2000
100	200	3000	2500	2000
Types V4H Single-Phase and V6H Three-Phase; 200 Amps Maximum				
5	10	200	200	200
10	20	400	400	400
15	30	600	600	600
25	50	1000	1000	1000
35	70	1400	1400	1400
50	100	2000	2000	2000
70	140	2800	2500	2000
100	200	3000	2500	2000
140	280	3000	2500	2000
200	400	3000	2500	2000
Type L Single-Phase; 280 Amps Maximum				
25	50	1500	1500	1500
35	70	2100	2100	2100
50	100	3000	3000	3000
70	140	4200	4200	4000
100	200	6000	5000	4000
140	280	6000	5000	4000
200	400	6000	5000	4000
280	560	6000	5000	4000
Type V4L Single-Phase; 280 Amps Maximum				
@ 2.4 through 14.4 kV				
5	10	300		
10	20	600		
15	30	900		
25	50	1500		
35	70	2100		
50	100	3000		
70	140	4200		
100	200	6000		
140	280	6000		
200	400	6000		
280	560	6000		
Type E Single-Phase; 100 Amps Maximum				
@ 24.9 kV				
5	10	300		
10	20	600		
15	30	900		
25	50	1500		
35	70	2100		
50	100	2500		
70	140	2500		
100	200	2500		

(continued)

Table 14 (continued)
Single- and Three-Phase Recloser Ratings

Trip-Coil Continuous Current (amps)	Minimum Trip Current (amps)	Interrupting Current (rms symmetrical amps)
Type 4E Single-Phase; 280 Amps Maximum		
@ 24.9 kV		
50	100	3000
70	140	4000
100	200	4000
140	280	4000
200	400	4000
280	560	4000
Type V4E Single-Phase; 280 Amps Maximum		
15	30	900
25	50	1500
35	70	2100
50	100	3000
70	140	4200
100	200	6000
140	280	6000
170	340	6000
200	400	6000
280	560	6000

RATINGS

Table 15
Duty Cycles

Type	% Interrupting Rating	Maximum Circuit X/R Ratio	Number Unit Operations	Total Unit Operations	Type	% Interrupting Rating	Maximum Circuit X/R Ratio	Number Unit Operations	Total Unit Operations
H	15-20	2	40	100	4E	15-20	3	32	64
	45-55	4	40			45-55	6	20	
	90-100	8	20			90-100	13	12	
4H, 6H	15-20	2	32	68	V4E	15-20	3	96	248
	45-55	5	24			45-55	7	120	
	90-100	10	12			90-100	15	32	
V4H, V6H	15-20	2	128	272	L	15-20	3	32	64
	45-55	5	96			45-55	6	20	
	90-100	10	48			90-100	12	12	
E	15-20	2	40	72	V4L	15-20	4	88	232
	45-55	5	20			45-55	8	112	
	90-100	12	12			90-100	15	32	

SPECIFICATIONS

Table 16
Specifications

	Recloser Type						
	H	4H 6H	V4H V6H	L	V4L	E	4E V4E
Nominal operating voltage (rms kV)	2.4—14.4	2.4—14.4	2.4—14.4	2.4—14.4	2.4—14.4	24.9	24.9
Maximum design voltage (rms kV) .	15.0	15.5	15.5	15.5	15.5	27	27
Impulse withstand (BIL), 1.2 x 50 sec wave (crest kV)	95	110	110	110	110	150	150
60-Hz withstand (rms kV)							
Dry one minute	35	50	50	50	50	60	60
Wet, ten seconds	30	45	45	45	45	50	50
Reclosing time (sec)	1	1 ½	1 ½	2	2	1 ½	2
Bushing creepage distance (in.).....	10 ¾	10 ¾	10 ¾	11 ¾	11 ¾	13 ¾	17

DIMENSIONS AND WEIGHTS

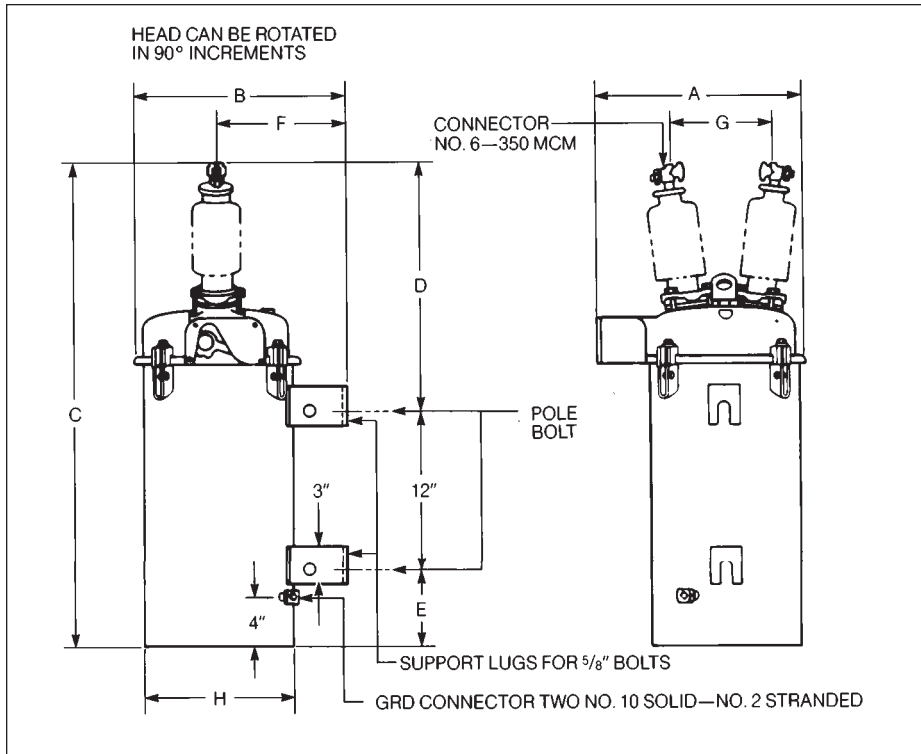

Figure 6.
Dimensions of Types 4H, V4H, L, V4L, E, 4E, and V4E reclosers.

Dimension (in.)	Recloser Type				
	4H,V4H	L	V4L	E	4E,V4E
A	14	15	15	15	15 ¹ / ₈
B	14 ⁵ / ₁₆	15 ⁷ / ₈	15 ⁷ / ₈	15 ⁷ / ₈	16
C	35 ¹ / ₂	37 ⁷ / ₈	45 ¹ / ₂	41 ¹ / ₂	49
D	16 ¹³ / ₁₆	18 ⁷ / ₈	18 ⁷ / ₈	20 ³ / ₈	22 ¹ / ₂
E	6 ¹¹ / ₁₆	6 ¹ / ₄	14 ⁵ / ₈	9 ¹ / ₈	14 ¹ / ₂
F	8 ³ / ₄	9 ³ / ₄	9 ³ / ₄	9 ³ / ₄	9 ³ / ₄
G	8 ¹ / ₂	11	11	11	11 ³ / ₄
H	9 ¹ / ₄	11 ¹ / ₄	11 ¹ / ₄	11 ¹ / ₄	11 ¹ / ₄

NOTE: Dimensions shown are for general information only. For critical construction dimensions, refer to factory. For dimensions of recloser with mountings, see Catalog 280-85.

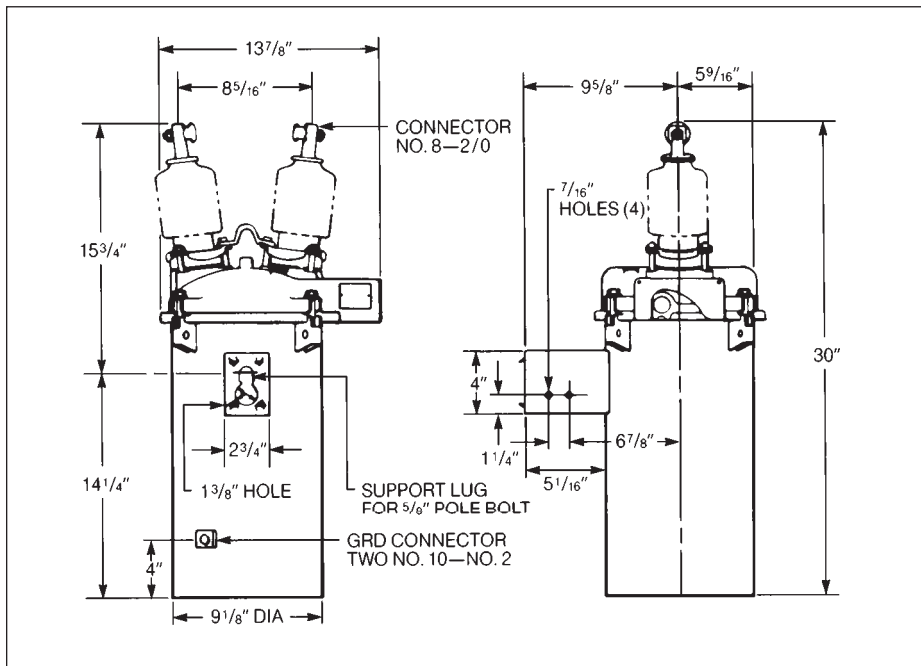

Figure 7.
Dimensions of Type H reclosers.

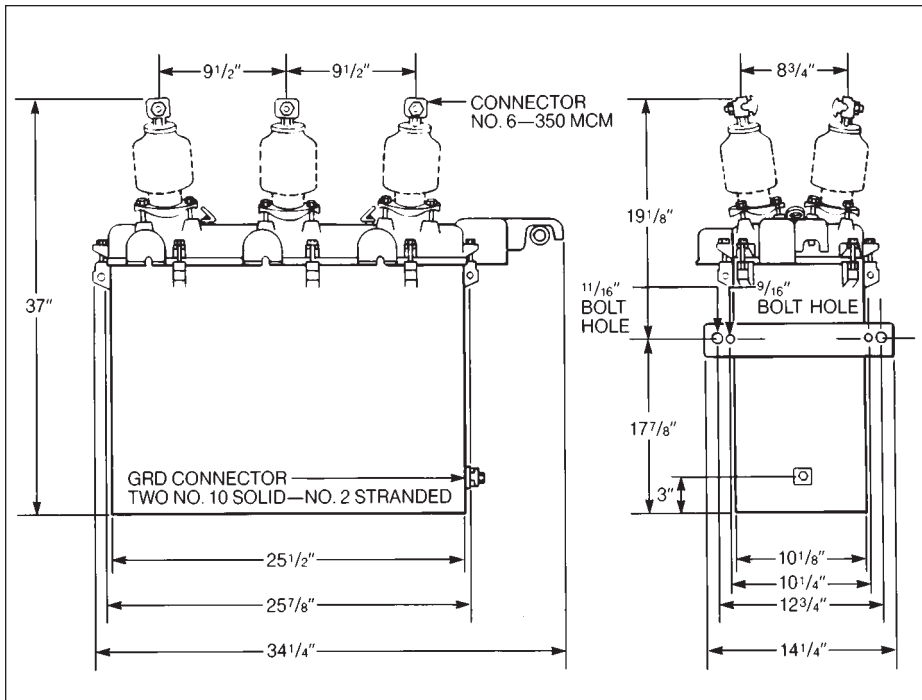

Figure 8.
Dimensions of Types 6H and V6H reclosers.

TABLE 17
Weights and Oil Capacity

	Recloser Type							
	H	4H, V4H	6H, V6H	L	V4L	E	4E	V4E
Weight; dry (lb)	55	76	236	106	142	107	142	147
Weight, with oil (lb) ..	85	114	394	159	205	169	205	210
Oil capacity (gal)	4	5	21	7	9 1/2	8 1/4	9 1/2	9 1/2